

For more detailed installation, configuration, programming, file transfer, and operating instructions, refer to the *NetLinX Integrated Controllers (NI-2100, NI-3100, and NI-4100 Series)* Instruction Manual, available online at [www.amx.com](http://www.amx.com).



**FIG. 1** NI-4100 NetLinX Integrated Controller (front view)

### Overview

The NI-4100 unit (**FG2105-06**) is geared toward those advanced control and automation requirements associated with most complex commercial and residential installations. The NI-4100 provides support for up to 4 NetLinX control cards (such as NXC-COM2, NXC-IRS4, etc.), 7 RS-232/RS-422/RS-485 Ports, 8 IR/Serial Output ports, 8 Digital Input/Output ports, and 8 Relays. The NI-4100's on-board Master also provides the ability to update installed control card firmware.

### ATTENTION!

**Verify you are using the latest NI firmware for the on-board Master. Verify you are using the latest version of NetLinX Studio (available for download from [www.amx.com](http://www.amx.com)).**

### Specifications

NI-4100 Specifications	
<b>Dimensions (HWD):</b>	<ul style="list-style-type: none"> <li>5.21" x 17.00" x 9.60" (13.23 cm x 43.18 cm x 24.27 cm)</li> <li>3 rack units high</li> </ul>
<b>Power Requirement:</b>	<ul style="list-style-type: none"> <li>900 mA @ 12 VDC</li> </ul>
<b>Memory:</b>	<ul style="list-style-type: none"> <li>64 MB SDRAM</li> <li>1 MB Non-volatile (NV) SRAM</li> </ul>
<b>Compact Flash:</b>	<ul style="list-style-type: none"> <li>128 MB Card (upgradeable) (refer to the Other AMX Equipment section for more information)</li> <li>Refer to the <i>NetLinX Integrated Controllers (NI-2100, NI-3100, and NI-4100 Series)</i> Instruction Manual for more information.</li> </ul>
<b>Weight:</b>	<ul style="list-style-type: none"> <li>9.15 lbs (4.15 kg)</li> </ul>
<b>Enclosure:</b>	<ul style="list-style-type: none"> <li>Metal with black matte finish</li> </ul>
<b>Certifications:</b>	<ul style="list-style-type: none"> <li>FCC Part 15 Class B, CE, and IEC 60950</li> </ul>
<b>Front Panel Components:</b>	<ul style="list-style-type: none"> <li>LINK/ACT: Green LED blinks when the Ethernet cables are connected and terminated correctly. Also blinks when receiving Ethernet data packets.</li> <li>Status: Green LED blinks to indicate that the system is programmed and communicating properly.</li> <li>Output: Red LED blinks when the Controller transmits data, sets channels On and Off, sends data strings, etc.</li> <li>Input: Yellow LED blinks when the Controller receives data from button pushes, strings, commands, channel levels, etc.</li> <li>RS-232/422/485 LEDs: Seven sets of red and yellow LEDs light to indicate the rear DB9 Ports 1 - 7 are transmitting or receiving RS-232, 422, or 485 data</li> <li>Relay LEDs: Eight red LEDs light to indicate the rear relay channels 1 - 8 are active (closed). These LEDs reflect the state of the relay on Port 8.</li> <li>IR/Serial LEDs: Eight red LEDs light to indicate the rear IR/Serial channels 1 - 8 are transmitting control data on Ports 9 - 16. LED indicator for each IR port remains lit for the length of time that IR/Serial data is being generated.</li> <li>I/O LEDs: Eight yellow LEDs light when the rear I/O channels 1 - 8 are active. LED indicator for each I/O port reflects the state of that particular port.</li> <li>NetLinX Control Card Slot 1 - 4: Accepts up to 4 compatible NetLinX Cards: such as the NXC-COM2, NXC-I/O10, etc.</li> <li>Rack-mount brackets: Provides an installation option for the Integrated Controller to be mounted into an equipment rack, when used with the Installation Kit (<b>KA2105-01</b>).</li> </ul>

### NI-4100 Specifications (Cont.)

<b>Rear Panel Connectors:</b>	<ul style="list-style-type: none"> <li>RS-232/422/485 (Ports 1 - 7): Seven RS-232/422/485 control ports using DB9 (male) connectors with XON/XOFF (transmit on/transmit off), CTS/RTS (clear to send/ready to send), and 300-115,200 baud.</li> <li>ICSNet: Two RJ-45 connectors for ICSNet interface (<b>included</b>).</li> <li>ICSHub Out: RJ-45 connector provides data to a Hub connected to the Controller (<b>included</b>).</li> <li>Relay (Port 8): 8-channel single-pole single throw relay ports with each relay being independently controlled and supporting up to 8 independent external relay devices.</li> <li>Digital I/O (Port 17): 8-channel binary I/O port for contact closure with each input being capable of voltage sensing. Input format is software selectable with interactive power sensing for IR ports.</li> <li>IR/Serial (Ports 9 - 16): Eight IR/Serial control ports support high-frequency carriers of up to 1.142 MHz with each output being capable of two electrical formats: IR or Serial. Eight IR/Serial data signals can be generated simultaneously. <i>IR ports support data mode (at limited baud rates and wiring distances).</i></li> <li>Program Port: RS-232 DB9 connector (male) can be connected to a DB9 port on a PC. This connector can be used with serial and NetLinX programming commands, as well as other DB9 capable devices, to both upload/download information from the NetLinX Studio program.</li> <li>Configuration DIP Switch: Sets the communication parameters for the Program port.</li> <li>ID Pushbutton: Sets the NetLinX ID (<b>Device only</b>) assignment for the device.</li> <li>Ethernet Port: LEDs show communication activity, connection status, speeds, and mode information: <ul style="list-style-type: none"> <li>SPD (speed) - Yellow LED lights On when the connection speed is 100 Mbps and turns Off when the speed is 10 Mbps.</li> <li>L/A (link/activity) - Green LED lights On when the Ethernet cables are connected and terminated correctly, and blinks when receiving Ethernet data packets.</li> </ul> </li> <li>AXlink LED: Green LED indicates the state of the AXlink port.</li> <li>AXlink Port: 4-pin 3.5 mm mini-Phoenix (male) connector that provides data and power to external control devices.</li> <li>Power Port: 2-pin 3.5 mm mini-Phoenix (male) connector.</li> <li>CardFrame Number DIP Switch: Sets the starting address for the Control Cards in the CardFrame. (<i>Factory default CardFrame DIP switch value = 0</i>). The Control Card address range is 1-3064.</li> <li>Control Card Connectors (1 - 4): 20-pin (male) connectors that connect the Control Cards and external equipment to the CardFrame.</li> </ul>
<b>Included Accessories:</b>	<ul style="list-style-type: none"> <li>2-pin 3.5 mm mini-Phoenix (female) PWR connector (41-5025)</li> <li>4-pin 3.5 mm mini-Phoenix (female) AXlink connector (41-5047)</li> <li>10-pin 3.5 mm mini-Phoenix (female) I/O connector (41-5107)</li> <li>Installation Kit (KA2105-01): <ul style="list-style-type: none"> <li>8-pin Relay Common Strip</li> <li>Four rack mount screws</li> <li>Four washers</li> <li>Quick Start Guide</li> <li>Two 8-pin 3.5 mm mini-Phoenix (female) Relay connectors (41-5083)</li> <li>Two CC-NIRC IR Emitters</li> <li>Two removable rack ears (62-2105-07)</li> </ul> </li> </ul>
<b>Other AMX Equipment:</b>	<ul style="list-style-type: none"> <li>2-pin 3.5 mm mini-Phoenix male connector (41-5026)</li> <li>CSB Cable Support Bracket (<b>FG517</b>)</li> <li>CC-NIRC IR cables (<b>FG10-000-11</b>)</li> <li>CC-NSER IR/Serial cables (<b>FG10-007-10</b>)</li> <li>NCK, NetLinX Connector Kit (<b>FG2902</b>)</li> <li>STS, Serial To Screw Terminal (<b>FG959</b>)</li> <li>Upgrade Compact Flash (factory programmed with firmware): <ul style="list-style-type: none"> <li>NXA-CF2NI256M - 256 MB compact flash card (<b>FG2116-47</b>)</li> <li>NXA-CF2NI512M - 512 MB compact flash card (<b>FG2116-48</b>)</li> <li>NXA-CF2NI1G - 1 GB compact flash card (<b>FG2116-49</b>)</li> </ul> </li> </ul>

### Connections and Wiring

FIG. 2 shows the layout of the connectors and components located on the rear of the NI-4100 NetLinX Integrated Controller.

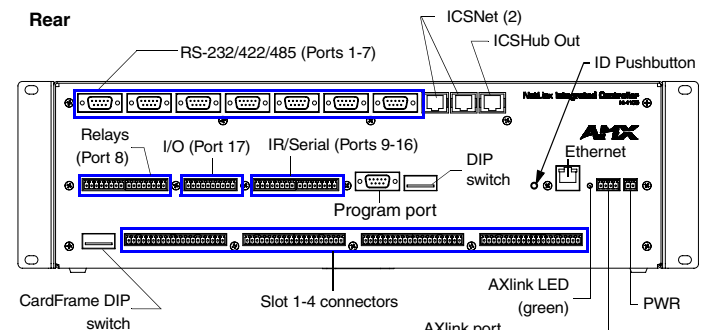

**FIG. 2** NI-4100 rear connectors and components

## Wiring a power connection

Use a 12 VDC-compliant power supply to provide power to the Integrated Controller through the rear 2-pin 3.5 mm mini-Phoenix. Use the power requirements information listed in the Specifications table to determine the power draw.

The incoming PWR and GND cable from the PSN power supply must be connected to their corresponding locations within the PWR connector.

## RS-232/422/485 wiring connector information

FIG. 3 shows the pinout and wiring specification information for the rear RS-232/RS-422/RS-485 (DB9) Device Ports. These ports support most standard serial mouse control devices and RS-232 communication protocols for PC data transmission (NI-4100 uses Ports 1 - 7).

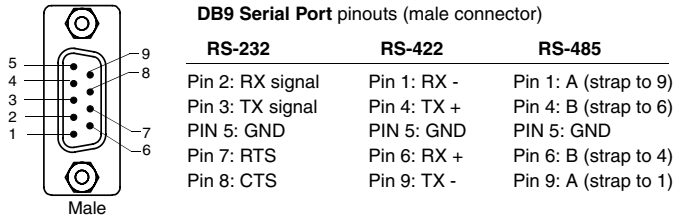

FIG. 3 RS-232/422/485 DB9 (male) connector pinouts

## RJ-45 Connections

Use a standard CAT5 Ethernet cable to provide communication between the Integrated Controller and external NetLinx devices.

## Ethernet 10/100 Base-T Connector

The Ethernet cable provides 10/100 network connectivity between the panel and the NetLinx Master.

## Baud Rate Settings

The Program Port DIP switch is located on the rear of the device. Use this DIP switch to set the baud rate for the Program Port, according to the settings shown in the following table. Make sure the baud rate you set matches the baud rate on your PC's NetLinx COM Settings before programming the unit. By default, the baud rate is set to 38,400 (bps).

Baud Rate Settings				
Baud Rate	Position 5	Position 6	Position 7	Position 8
9600 bps	OFF	ON	OFF	ON
38,400 bps (default)	OFF	ON	ON	ON
57,600 bps	ON	OFF	OFF	OFF
115,200 bps	ON	ON	ON	ON

**Note:** DIP switch 1 activates/deactivates the Program Run Disable Mode. DIP Switches 2,3, and 4 must remain OFF at all times.

## Inserting NetLinx Cards into the NetLinx Control Card Slots

NetLinx Cards can be installed into the front card slots. The cards mount horizontally through the card slot openings on the front panel of the enclosure. To install a NetLinx Card:

1. Discharge the static electricity from your body by touching a grounded metal object and unplug all the connectors from the unit.
2. Remove the three screws by turning them in a counter-clockwise direction and remove the front faceplate.
3. Align the edges of the card with the internal guide slots and gently slide it in all the way until the rear edge of the card snap into place.
4. Re-secure the faceplate by inserting the three screws by turning them in a clockwise direction and securing the front faceplate to the Integrated Controller.
5. Re-apply power and other connections as necessary.

## Setting the Integrated Controllers' starting Card Address

The rear 8-position CardFrame Number DIP switch, lower-left rear of the Integrated Controller, sets the starting address (the device number in the D:P:S specification) for the Control Cards installed in the controller. The Control Card address range is 1 - 3064.

The factory default CardFrame DIP switch value = 0 (All CardFrame DIP switches in the OFF position).

The formula for setting the starting address is:

$$(DIP\ switch\ value) + Card\ slot\ Number\ (1 - 4) = Card\ Address$$

For example:

**A DIP switch setting of 00010101: (0 + 0 + 0 + 96 + 0 + 384 + 1536) + SLOT #(ex:1) = 2017. A card in slot number 1 = device address 2017.**

Set the CardFrame Number DIP switch value is based on the table below.

Position	1	2	3	4	5	6	7	8	
Value	12	24	48	96	192	384	768	1536	ON position

**Cycle power to the unit for approximately 5 seconds. This allows the unit to read the new device number settings.**

## Preparing the NI-4100 for Serial Communication

1. Launch NetLinx Studio 2.x (default location is **Start > Programs > AMX Control Disc > NetLinx Studio 2 > NetLinx Studio 2**).
2. Select **Settings > Master Communication Settings**, from the Main menu, to open the *Master Communication Settings* dialog box.
3. Click the **Communications Settings** button to open the *Communications Settings* dialog.
4. Click the **NetLinx Master** radio button (from the Platform Selection section) to indicate you are working with a NetLinx Master.
5. Click the **Serial** radio button (from the Transport Connection Option section) to indicate you are connecting to the Master via a COM port.
6. Click the **Edit Settings** button (on the *Communications Settings* dialog) to open the *Serial Settings* dialog and set the COM port parameters (used to communicate to the NetLinx Master).
7. Click the **OK** button three times to return to the main application.
8. Right-click the **Online Tree** tab entry and select **Refresh System**.
9. Assign a System Value by using **Diagnostics > Device Addressing** from the Main menu.
10. Enable the **Change System selection** by clicking on it and then enter the current and new System values.
11. Click the **Change Device/System Number** button and when finished click **Done**.
12. Select **Tools > Reboot the Master Controller** to access the *Reboot the Master* dialog, then click **Reboot** to restart the Master and incorporate any changes.
13. Once the dialog replies with "Reboot of system complete", click **Done** and then click the **OnLine Tree** tab in the Workspace window to view the devices on the System. *The default System value is one.*
14. Right-click on the *Empty Device Tree/System* entry and select **Refresh System** to re-populate the list.

## Configuring the NI-4100 for Ethernet Communication

**Before continuing, complete the COM port steps above.**

1. Connect an Ethernet cable to the unit's rear Ethernet connector.
2. Select **Diagnostics > Network Address** from the Main menu and enter the System, Device (0 for a Master), and Host Name information.
3. To configure the Address:
  - Use a DHCP Address by selecting the **Use DHCP** radio button, then click the **GET IP** button (to obtain a DHCP Address from the DHCP Server), click the **SET IP Information** button (to retain the new address), and then finish the process by clicking the **Reboot Master > OK** buttons.
  - Use a Static IP Address by selecting the **Specify IP Address** radio button, enter the IP parameters into the available fields, then click the **SET IP Information** button (to retain the pre-reserved IP Address to the Master), and then click the **Reboot Master > OK** buttons to finish the process.
4. Repeat steps 1 - 5 from the previous section but rather than selecting the **Serial** option, choose **TCP/IP** and edit the settings to match the IP Address you are using (whether Static or IP).
5. Click on the **Authentication Required** radio box (if the Master is secured) and press the **User Name and Password** button to enter a valid username and password being used by the secured Master.
6. Click the **OK** button three times to return to the main application.

For full warranty information, refer to the AMX Instruction Manual(s) associated with your Product(s).

060-004-2948 05/06

©2006 AMX. All rights reserved. AMX and the AMX logo are registered trademarks of AMX.

AMX reserves the right to alter specifications without notice at any time.

3000 RESEARCH DRIVE, RICHARDSON, TX 75082 • 800.222.0193 • fax 469.624.7153 • technical support 800.932.6993 • www.amx.com

93-2105-06 REV: B

